



INSTALLATION INSTRUCTIONS FOR PART 99-7012

APPLICATIONS

MITSUBISHI Galant 2004-2010 (with auto climate control)

99-7012



KIT FEATURES

- DIN Radio Provision with Pocket
- ISO Mount Radio Provision with Pocket
- Double DIN Radio Provision
- Stacked ISO Mount Units Provision

KIT COMPONENTS

- A) Radio Housing • B) ISO Brackets • C) Trim Plate • D) Double DIN Brackets
- E) Double DIN Trim Plate • F) Snap in Pocket

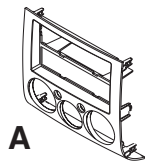

A

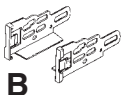

B



C



D



E

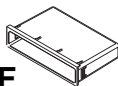

F

Harness & Antenna Connections (sold separately)

- 70-7001 - Mitsubishi Harness 92-up

TOOLS REQUIRED:

- Phillips Screwdriver/ Panel Removal Tool
- Socket Set • Cutting Tool



1-800-221-0932



www.metraonline.com

© COPYRIGHT 2007-2010 METRA ELECTRONICS CORPORATION



TABLE OF CONTENTS

Dash Disassembly

- Mitsubishi Galant 2004-2010(with auto climate control) 1

Kit Preparation 2

Kit Assembly

- DIN Radio Provision with Pocket 2

- ISO Mount Radio Provision with Pocket. 3

- Double DIN Radio Provision/Stacked ISO Mount Units Provision 4

Final Assembly 5

Note:

Refer also to the instructions included with the aftermarket radio.

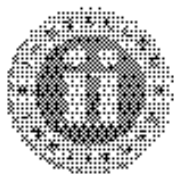

KNOWLEDGE IS POWER
Increase your satisfaction and satisfaction skills by
installing the most recognized and respected
mobile electronics brand in our industry.
Log onto www.metradirect.com or call
800-894-4377 for more information and take steps
toward a better tomorrow.

MITSUBISHI GALANT 2004-2010

- 1** Disconnect the negative battery terminal to prevent an accidental short circuit.
- 2** Unclip the radio trim panel including the climate controls and radio controls. Unplug and remove the panel. (Figure A)
- 3** Remove (4) Phillips screws securing radio chassis to sub dash. Unplug and remove the chassis. (Figure B)
- 4** Remove (4) Phillips screws securing the climate controls to the radio panel. Remove the climate controls and retain the screws and the climate controls for reinstallation during kit assembly. (Figure C)

Continue to kit assembly

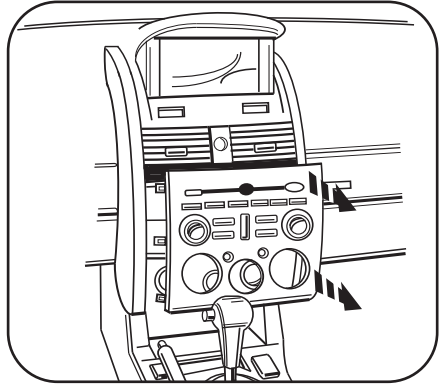
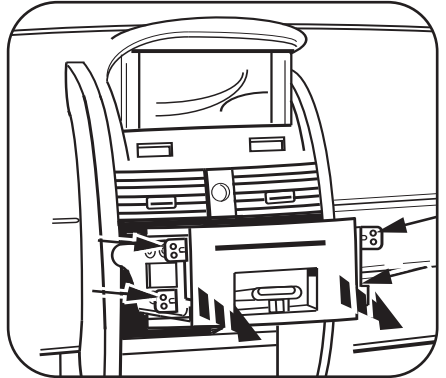
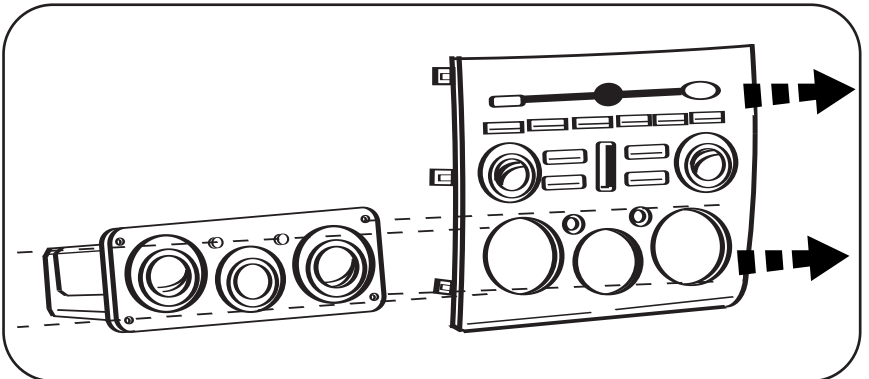
A

B

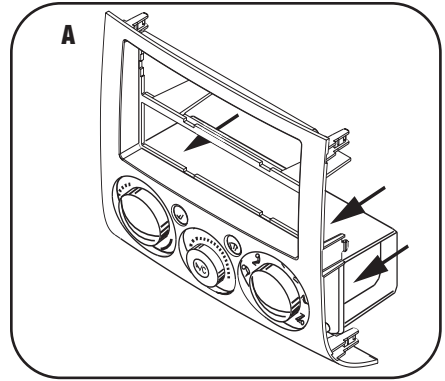
C

- 1 Secure the climate controls to the radio housing using the factory hardware. (Figure A)



DIN RADIO PROVISION WITH POCKET

**Note: Refer also to the instructions included with the aftermarket radio.*

- 1 Slide the DIN cage into the radio housing and secure by bending the metal locking outward. (Figure A)
- 2 Slide the aftermarket radio into the cage until it snaps into place. (Figure B)
- 3 Snap the pocket into the radio housing. (Figure C)

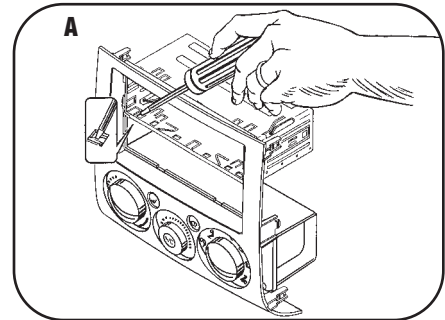

Continue to final assembly.

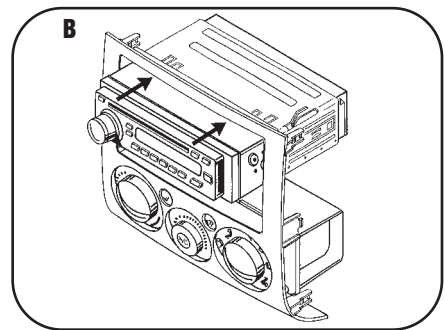
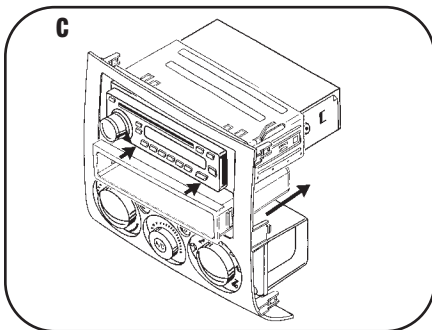

ISO MOUNT RADIO PROVISION WITH POCKET

**Note: Refer also to the instructions included with the aftermarket radio.*

- 1 Mount the ISO Brackets to the radio using the screws supplied with the radio. (Figure A)
- 2 Slide the radio/bracket assembly into the radio housing until it snaps into place. (Figure B)
- 3 Snap the trim plate onto the front of the radio housing. (Figure B)
- 4 Snap the Pocket into the radio housing. (Figure C)

Continue to final assembly.

A

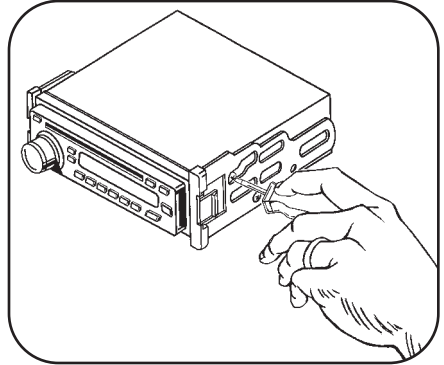

B

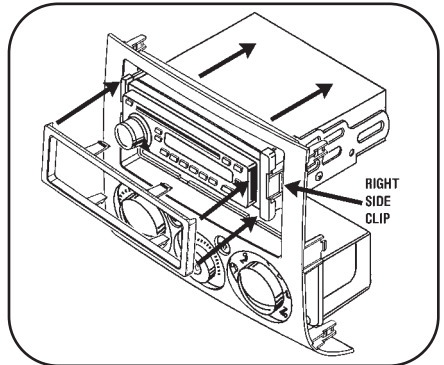

C

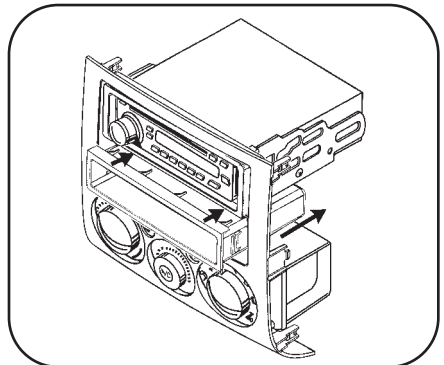

DOUBLE DIN RADIO PROVISION STACKED ISO MOUNT UNITS PROVISION

****Note: Refer also to the instructions included with the aftermarket radio.***

- 1** Cut and remove the center bar from the radio housing. (Figure A)
- 2** Snap the Double DIN brackets to the inside edge of the radio housing. (Figure B)
- 3** Slide the Double DIN radio or stacked ISO mount units into the bracket/radio housing assembly and secure the radio or stacked ISO mount units to the assembly using the screws supplied with the radio or the ISO mount units. (Figure C)
- 4** Snap the Double DIN trim plate onto the front of the radio/housing assembly. (Figure C)

Continue to final assembly.

A

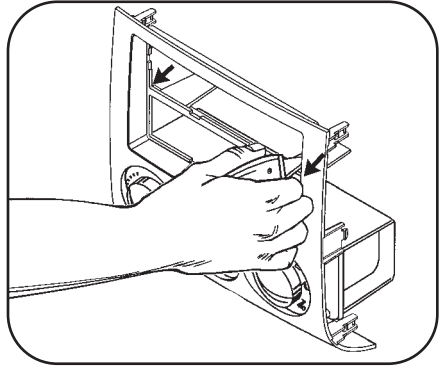

B

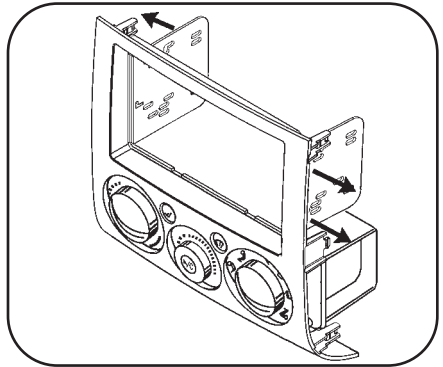

C

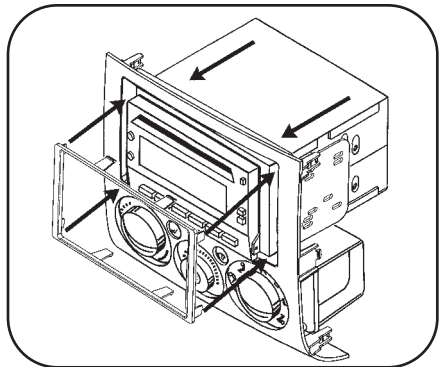

FINAL ASSEMBLY

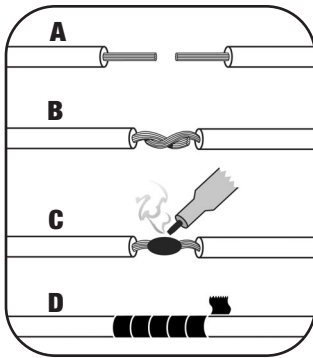

- (A) Strip wire ends back 1/2"**
- B) Twist ends together**
- C) Solder**
- D) Tape**

- 1** Locate the factory wiring harness in the dash. Metra recommends using the proper mating adapter and making connections as shown. (Isolate and individually tape off the ends of any unused wires to prevent electrical short circuit.)
- 2** Re-connect the negative battery terminal and test the unit for proper operation.
- 3** Reassemble radio and dash assemblies in reverse order of disassembly.

FINAL WIRING CONNECTIONS

Make wiring connections using the EIA color code chart shown below and the instructions included with the head unit. Metra recommends making connections as shown below; Strip, Splice, Solder, Tape. Isolate and individually tape off ends of any unused wires to prevent electrical short circuit.

METRA / EIA WIRING CODE

12V Ignition / Acc.	Red	Right Front (+)	Gray
12V Batt / Memory.	Yellow	Right Front (-).	Gray/ Black
Ground.	Black*	Left Front (+)	White
Power Antenna.	Blue	Left Front (-).	White / Black
Amp Turn-On	Blue / White	Right Rear (+)	Violet
Amp Ground.	Black / White	Right Rear (-).	Violet / Black
Illumination	Orange	Left Rear (+)	Green
Dimmer	Orange / White	Left Rear (-)	Green / Black

***NOTE:** When a Black wire is not present, ground radio to vehicle chassis.
 All colors may not be present on all leads due to manufacturer's specifications.

99-7012 INSTRUCTIONS



1-800-221-0932



www.metraonline.com

REV. 04/22/10 © COPYRIGHT 2007-2010 METRA ELECTRONICS CORPORATION INST99-7012