



## INSTALLATION INSTRUCTIONS FOR PART 95-7322

### APPLICATIONS

# Hyundai Azera 2006-2009

# 95-7322

#### KIT FEATURES

- Double DIN Radio Provision
- Stacked ISO Units Provision



#### KIT COMPONENTS

A) Double Din Trim Plate • B) Double DIN Brackets

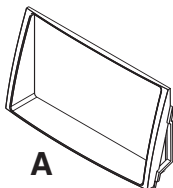

A

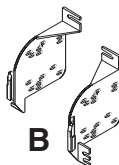

B

#### WIRING AND ANTENNA CONNECTIONS (Sold Separately)

##### Wiring Harness:

- 70-1004 - Hyundai/KIA harness 2004-up
- 70-7303 - Hyundai/KIA harness 2009

##### Antenna Adapter:

- 40-KI10 KIA antenna adapter 2007-up

#### TOOLS REQUIRED:

Small Flat Blade Screwdriver/ Panel Removal Tool

- Phillips Screwdriver



1-800-221-0932



[www.metraonline.com](http://www.metraonline.com)

© COPYRIGHT 2004-2009 METRA ELECTRONICS CORPORATION



**TABLE OF CONTENTS**

**Dash Disassembly**

**- Hyundai Azera 2006-07 ..... 1,2**

**Kit Assembly**

**- Double DIN Radio Provision ... 3**

**- Stacked ISO Units Provision ..... 4**

**Final Assembly ..... 5**

**\*Note:**

**Refer also to the instructions included with the aftermarket radio.**



**KNOWLEDGE IS POWER**

Enhance your installation and fabrication skills by enrolling in the most recognized and respected mobile electronics school in our industry. Log onto [www.installerinstitute.com](http://www.installerinstitute.com) or call 800-354-6782 for more information and take steps toward a better tomorrow.

## HYUNDAI AZERA 2006-2009

- 1** Disconnect the negative battery terminal to prevent an accidental short circuit.
- 2** Remove (1) Phillips head screw from bottom right hand corner then unclip and let the panel below the steering column hang. (Figure A)
- 3** Remove (1) Phillips screw from the lower left side of the radio panel behind panel removed in step 2. (Figure B)
- 4** Unclip and remove the trim panel above the radio that extends across the dash to the passenger side. (Figure C)

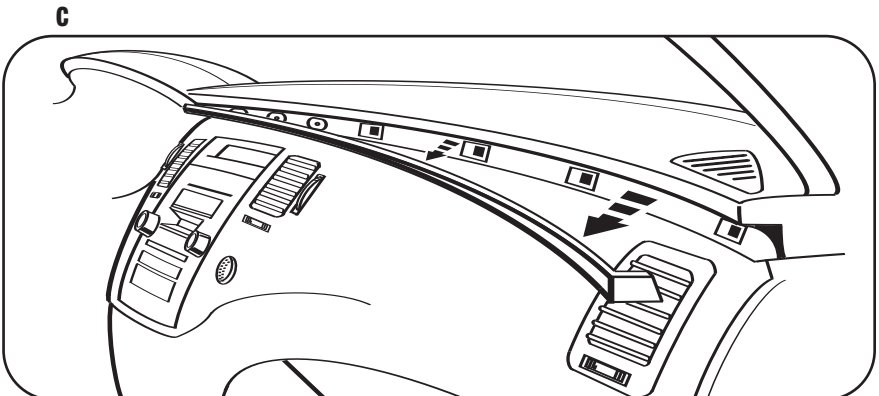
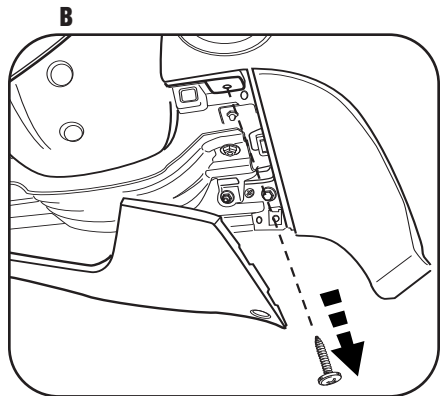
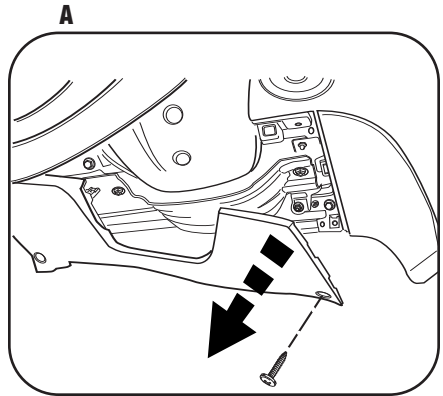

## HYUNDAI AZERA 2006-2009

- 5** Remove (3) Phillips screws from the top of the radio trim panel. (Figure D)
- 6** Remove (2) Phillips screws from under radio trim panel. (Figure E)
- 7** Unclip and remove the entire trim panel surrounding the radio. (Figure F)
- 8** Remove (4) Phillips screws securing the radio. Unplug and remove radio. (Figure G)

*Continue to kit assembly.*

**D**

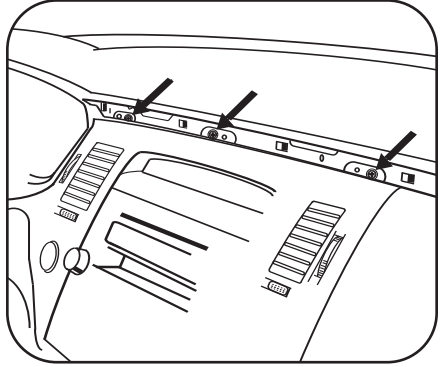

**E**

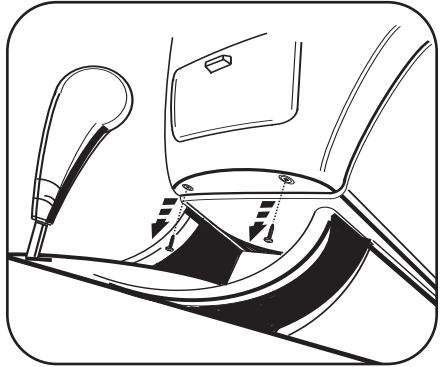

**G**

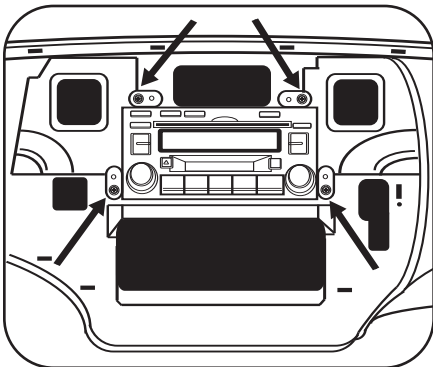

**F**

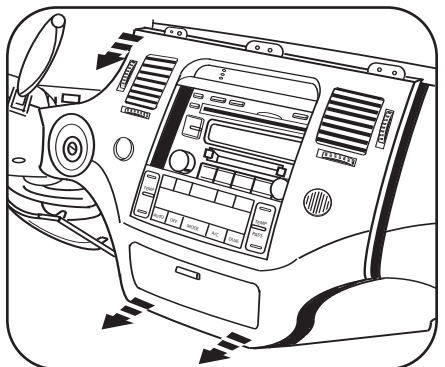

## DOUBLE DIN RADIO PROVISION

*\*Note: Refer also to the instructions included with the aftermarket radio.*

- 1 Snap the Double DIN brackets to the outside edge of the Double DIN trim plate. (Figure A)
- 2 Slide the Double DIN radio into the bracket/trim plate assembly and secure the radio to the assembly using the screws supplied with the radio. (Figure B)

*Continue to final assembly.*

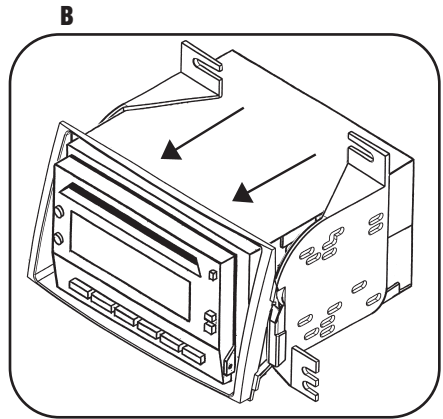
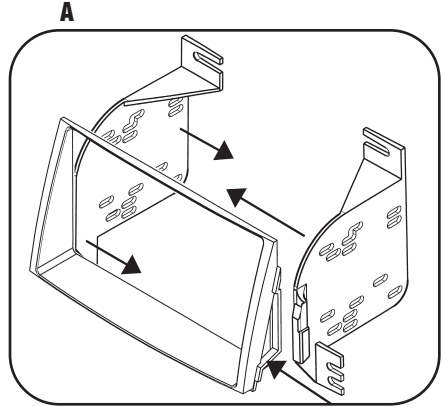

**STACKED ISO UNITS PROVISION**

*\*Note: Refer also to the instructions included with the aftermarket radio.*

- 1 Snap the Double DIN brackets to the outside edge of the Double DIN trim plate. (Figure A)
- 2 Slide the stacked ISO units into the bracket/radio housing assembly and secure the units to the kit using the screws supplied with the units. (Figure B)

*Continue to final assembly.*

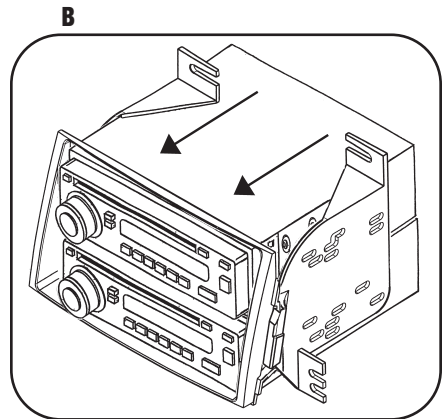
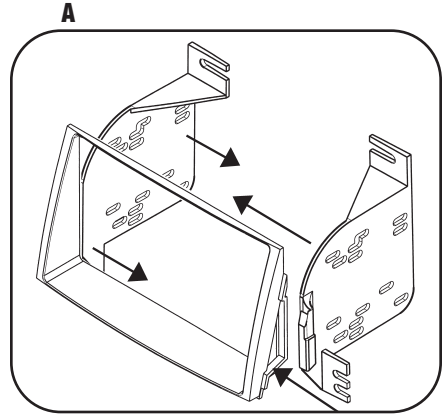

## FINAL ASSEMBLY

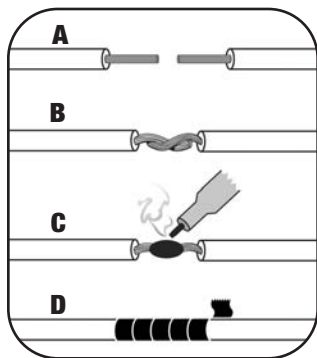

**(A) Strip wire ends back 1/2"**

**B) Twist ends together**

**C) Solder**

**D) Tape**

- 1** Locate the factory wiring harness in the dash. Metra recommends using the proper mating adapter and making connections as shown. (Isolate and individually tape off the ends of any unused wires to prevent electrical short circuit.)
- 2** Re-connect the negative battery terminal and test the unit for proper operation.
- 3** Reassemble radio and dash assemblies in reverse order of disassembly.

### FINAL WIRING CONNECTIONS

Make wiring connections using the EIA color code chart shown below and the instructions included with the head unit. Metra recommends making connections as shown below; Strip, Splice, Solder, Tape. Isolate and individually tape off ends of any unused wires to prevent electrical short circuit.

#### METRA / EIA WIRING CODE

12V Ignition / Acc. . . . . Red	Right Front (+) . . . . . Gray
12V Batt / Memory. . . . . Yellow	Right Front (-). . . . . Gray/ Black
Ground. . . . . Black*	Left Front (+) . . . . . White
Power Antenna. . . . . Blue	Left Front (-). . . . . White / Black
Amp Turn-On . . . . . Blue / White	Right Rear (+) . . . . . Violet
Amp Ground. . . . . Black / White	Right Rear (-) . . . . . Violet / Black
Illumination . . . . . Orange	Left Rear (+) . . . . . Green
Dimmer . . . . . Orange / White	Left Rear (-) . . . . . Green / Black

**\*NOTE:** When a Black wire is not present, ground radio to vehicle chassis.

All colors may not be present on all leads due to manufacturer's specifications.

# 95-7322 INSTRUCTIONS



**1-800-221-0932**  **[www.metraonline.com](http://www.metraonline.com)**

REV. 05/29/09 © COPYRIGHT 2004-07 METRA ELECTRONICS CORPORATION

INST95-7322